



Church safety solutions

Created in cooperation with the United Church of Christ Insurance Board

December 2007

Inside this issue

Working to keep your holiday season a safe one

Controlling Holiday Losses

- Earth: slip, trip and fall exposures
- Wind: roof damage, trees falling
- Fire: furnaces, heaters, candles, seasonal decorations
- Water: leaking roofs, frozen pipes, clogged gutters, ice dams1

“Lessons of loss”: Real-life examples of costly (and preventable) church losses5

Coming soon: January – Material Handling Safety and Safe Lifting Methods

Controlling holiday losses

Among all the activities your church has during this busy holiday season, consider the impact an accident or building damage could have at this time of the year. Over the past five Christmas holiday seasons – earth, wind, fire and water exposures have accounted for 1,454 claims and \$19.7 million in losses to Zurich insured Church customers. For this period of time, these categories account for 34 percent of all Zurich Church claims and 64 percent of all Zurich church losses. This end-of-year publication is intended to provide church leaders with basic risk reduction strategies to address the following loss elements:

- Earth: Slip, trip, falls
- Wind: Roof damage, trees falling
- Fire: furnaces, heaters, candles, seasonal decorations
- Water: leaking roofs, frozen pipes, clogged gutters, ice dams

By assessing, correcting, and validating the controls for these loss factors, you can help your church members and guests enjoy the holiday season.

(Continued on page 2)



Controlling holiday losses *(continued)*

Assess	Correct	Validate
Slip/fall – Water drainage, ice/snow removal, lighting, handrails, frayed carpet, uneven surfaces, poorly marked changes in walking surface	Slip/fall – Clear gutters, re-direct downspouts, use mats/salt where water/ice is prevalent, adjust lighting (including timers), fix/remove trip hazards, highlight changes in walking surfaces	Slip/fall – Review problems/solutions with janitorial staff, re-inspect problem and high-traffic areas, including during services, mutual inspection with neighboring church
Wind – Inspect roof(shingles lifted up, flashing secured), inspect overhanging tree limbs, inspect rooftop equipment	Wind – Arrange for spot roof repairs as soon as possible, arrange for overhanging tree limbs to be cut back, do not work on ladders during high-wind conditions	Wind – Oversee roof repairs or tree limb trimming, get repairs or work in writing
Fire – Condition of heating units, lightning protection, location and duration of lit candles, condition of cooking equipment, location of combustible decorations, condition of fire detection/suppression and building security systems	Fire – Arrange for heating contractor inspections, tighten connections and remove corrosion of lightning protection, allow lit candles only when church is occupied, inspect cooking equipment and keep it clear of grease, separate combustible decorations at least 4' from heat sources, ensure fire systems are operational, ensure building secure from unauthorized entry	Fire – Get repairs/work in writing from all outside contractors, enforce lock-up procedure for last ones in church, re-inspect for fire hazards, re-test fire alarms & systems
Water – Inspect roof for ponding/cracking/excessive wear, inspect gutters and downspouts for blockage, identify piping susceptible to freezing, inspect plumbing fixtures for existing leaks	Water – Correct any roofing/ gutter/downspout problems that can be easily remedied, insulate/heat water piping or allow water to run during freezing conditions, fix small plumbing leaks which could escalate when large holiday crowds come	Water – Oversee repairs, get repair work in writing, check on piping during freezing temps, clear out gutters and downspouts and direct water away from building

EARTH - Floor mats help reduce slips and falls

There are usually two solutions to every safety problem. One is to “engineer it out;” the second is to rely upon awareness and human nature to solve the problem. The latter of the two strategies is the least reliable means of reducing exposures, as it depends upon an individual recognizing a hazard, usually through use of a sign or something else that creates awareness of the hazard. Engineering

away the exposure is a better solution. For instance, if a floor is wet, placing a sign provides notice of the hazard, but does not remove the problem. A better solution is to clean the floor and dry it. Better yet, create a strategy for an engineering solution that will prevent hard floor surfaces from ever getting wet.

Using floor matting is a great example of a way to keep hard floor surfaces dry. Floor mats should be placed at all entrances with coverage extending over the greatest amount

Controlling holiday losses *(continued)*

of floor surface possible; typically ten to fifteen feet into the building is sufficient. The number and placement of floor mats is equally important. Overlapping mats can create a tripping hazard. If you must use multiple mats

Suggested configurations:

to cover the floor surface, ensure that they are adhered to the floor or have a non-skid backing to prevent movement. Warning signs and cones provide some support and should be placed in the area as soon as the weather turns inclement.

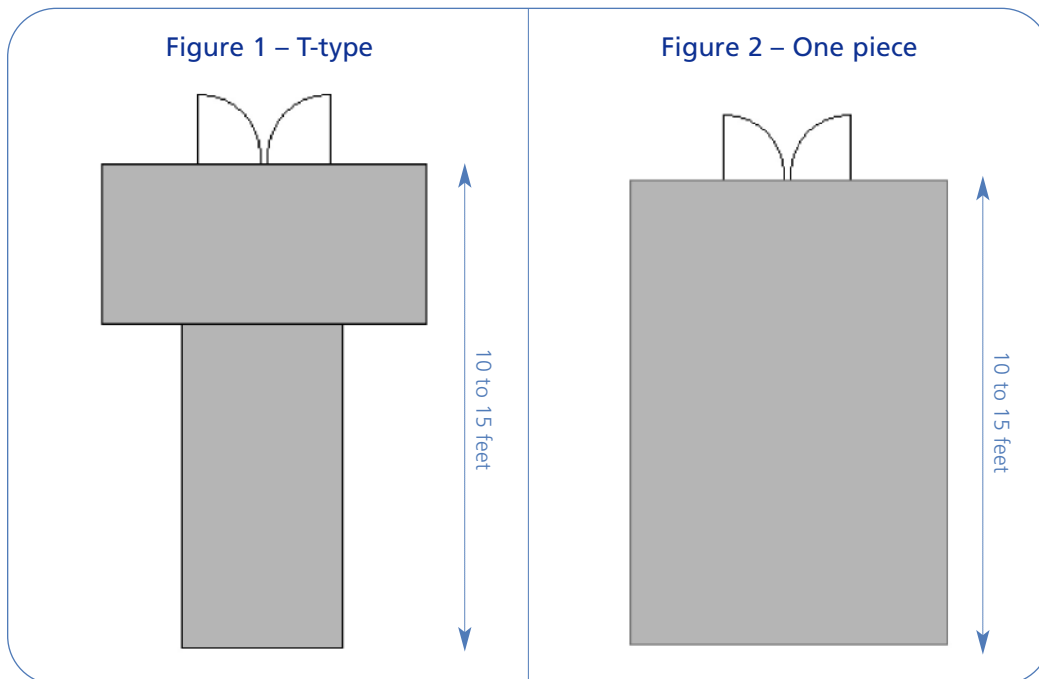

WIND - Secure rooftop equipment

Rooftop equipment can become detached during high winds, allowing water to enter the building at the openings left by the displaced equipment. The displaced equipment can then blow around the roof structure and puncture and tear roof coverings, impacting a church's ability to use the building. Worse yet, equipment blown off a roof can damage other buildings and injure people. Protective vents may also allow water to damage air

conditioning condensers and fans to the extent they may no longer provide service to the building.

A licensed roofing contractor can provide advice on securing rooftop equipment so costly damages can be avoided. If you aren't sure whether your church is at risk from high winds, check with your local building official, city engineer or planning and zoning administrator. They can tell you whether you are in an area where these high wind events occur. In addition, they can usually tell you how to protect your church property from high winds.

Controlling holiday losses (continued)

FIRE - Candle fire prevention

When using candles during church services, it is important to extinguish all candles between services. A candle that is left burning on an altar or holder can tip over or ignite nearby materials. Keep burning candles away from church podiums and furniture, tablecloths, drapes, carpets, books, paper and flammable decorations: The National Fire Protection Association recommends a four feet separation.

Churches are encouraged to read and carefully follow all manufacturer instructions, which often include trimming candlewicks to 1/4 inch each time before burning to prevent uneven burning and dripping wax. Candleholders specifically designed for candle use will help catch any dripping wax and embers that may drop from the wick. Churches should also attempt to prevent drafts during use of candles so that flames and wax are not blown across to combustible materials. One of the safest ways to extinguish a candle is to use a candlesnuffer, which helps prevent hot wax from spattering when being blown out. Churches should also have smoke detectors in every room where candles are burned.

WATER- Clean out roof gutters

Churches are encouraged to hire licensed and insured contractors to clean out all debris from the roof, gutters and roof drains, being careful not to damage the shingles. (If a church uses volunteer or employees for this task, please refer to Church Safety Solutions's March edition on working from heights and April

edition on roof inspection and maintenance.) Debris not only holds water, but can also clog roof drains, which can deteriorate the roof. Debris should be carefully swept off asphalt shingle roofs. The small sanded granules on asphalt shingles can come off very easily. Knocking these will shorten the life of the roof. Shingle keyways (spaces between shingles) should be inspected for signs of deterioration. Clogged roofs, drains and gutters can allow water to pond on roof structures and allow water to breach the roof structure. Water always finds the lowest point of gravity and, unfortunately, usually through a roof that is damaged or old.



Lessons of loss

The following “Lessons of Loss” are taken from real events reported to Zurich. Certain details have been changed to protect the anonymity of those involved.

Advent candles cause church fire

Following the last church service of the day, a volunteer, who typically extinguishes the candles forgot to perform this simple but very important task for the church's advent candles. The five candles of the advent wreath were placed on a flammable wreath centerpiece made of Styrofoam and dry greenery. On Monday morning, a church worker discovered that a fire had occurred and had apparently burned itself out, but not before causing considerable smoke damage to the ventilation system and furnishings throughout the church building. As the air circulated through the ducts, the soot and smoke carried to other areas of the church. The heaviest area of smoke contamination and residue was in the sanctuary area. The fire not only caused damage from smoke, but also interrupted further services until the building could be thoroughly cleaned. The church was not protected by a fire sprinkler system, smoke detectors, or monitoring by a central alarm service. Damages to the church property exceeded \$59,000.

Lessons learned: Churches can help prevent such losses by ensuring that there is a double check to ensure candles are extinguished, particularly in churches without sprinkler protection or smoke alarms. Churches should consider having sprinkler systems and smoke detectors installed that are monitored through a central station alarm company. When possible, use fire resistant material near candles and other fire sources.

Slip and fall on ice

A person (non-member) slipped and fell due to ice on the sidewalk in front of a church. The injured person fractured a kneecap and elbow, requiring extensive medical treatment and rehab. Although there was no precipitation on the day of the injury, there had been snowfall several days earlier. The injured person claimed that snow and ice fell from the church's steeple onto the sidewalk, melted and then refroze. The church claimed that they did remove snow and ice from the sidewalk earlier in the day and placed salt on the sidewalk. Initially, the church claimed that the city was responsible for the sidewalk snow removal, but it turned out not to be the case. The church had a procedure for snow/ice removal once there was 2" of accumulation, but apparently additional snow and ice fell from their building onto the sidewalk after the church removed some earlier in the day. Usually, the church cordoned off this section of sidewalk when it became icy, but did not do so on the date of the injury. The injured person's claim against the church was settled for \$400,000.

Lessons learned: Responsibility of sidewalks varies by municipality – confirm what the statutes are in your city. Through your routine self-inspections, determine if water (including snow and ice melt) is draining away from your building to a safe location. This church established good procedures for handling snow and ice, but did not fully follow those steps on the date of injury. For this and other risks, consider what is foreseeable to happen, and then work to control those risks with measures that are reasonable and no less than what would normally be expected.

Survey

Church Safety Solutions is one way Zurich works to assist you in your ongoing risk reduction efforts. By completing the following survey, you can help Zurich best fit our 2008 efforts to your church's needs.

1) The following topics are ones I would like to see Zurich address in 2008:

Recreational liability (such as injuries from sports games, camping, social events)	<input type="radio"/>	<input type="radio"/>	<input type="radio"/>	<input type="radio"/>	<input type="radio"/>
	Strongly disagree	Somewhat disagree	Undecided	Somewhat agree	Strongly agree
Lightning (protection for people and property)	<input type="radio"/>	<input type="radio"/>	<input type="radio"/>	<input type="radio"/>	<input type="radio"/>
	Strongly disagree	Somewhat disagree	Undecided	Somewhat agree	Strongly agree
Contractual liability (third-party use of facilities, service contractors)	<input type="radio"/>	<input type="radio"/>	<input type="radio"/>	<input type="radio"/>	<input type="radio"/>
	Strongly disagree	Somewhat disagree	Undecided	Somewhat agree	Strongly agree
Special event planning & control (all church events, events for the community)	<input type="radio"/>	<input type="radio"/>	<input type="radio"/>	<input type="radio"/>	<input type="radio"/>
	Strongly disagree	Somewhat disagree	Undecided	Somewhat agree	Strongly agree
Directors and officers liability (what is this, how do we protect our church)	<input type="radio"/>	<input type="radio"/>	<input type="radio"/>	<input type="radio"/>	<input type="radio"/>
	Strongly disagree	Somewhat disagree	Undecided	Somewhat agree	Strongly agree
Mission/field trip safety	<input type="radio"/>	<input type="radio"/>	<input type="radio"/>	<input type="radio"/>	<input type="radio"/>
	Strongly disagree	Somewhat disagree	Undecided	Somewhat agree	Strongly agree

2) The following media is effective for me and my organization to receive information:

Church Safety Solutions (newsletter)	<input type="radio"/>	<input type="radio"/>	<input type="radio"/>	<input type="radio"/>	<input type="radio"/>
	Strongly disagree	Somewhat disagree	Undecided	Somewhat agree	Strongly agree
Webinar (live presentation accessed via the Internet)	<input type="radio"/>	<input type="radio"/>	<input type="radio"/>	<input type="radio"/>	<input type="radio"/>
	Strongly disagree	Somewhat disagree	Undecided	Somewhat agree	Strongly agree
DVD or video (that can be downloaded or streamed via the Internet)	<input type="radio"/>	<input type="radio"/>	<input type="radio"/>	<input type="radio"/>	<input type="radio"/>
	Strongly disagree	Somewhat disagree	Undecided	Somewhat agree	Strongly agree
Training presentation (in my area)	<input type="radio"/>	<input type="radio"/>	<input type="radio"/>	<input type="radio"/>	<input type="radio"/>
	Strongly disagree	Somewhat disagree	Undecided	Somewhat agree	Strongly agree
One-on-one consultation	<input type="radio"/>	<input type="radio"/>	<input type="radio"/>	<input type="radio"/>	<input type="radio"/>
	Strongly disagree	Somewhat disagree	Undecided	Somewhat agree	Strongly agree
Group discussion (with peer churches)	<input type="radio"/>	<input type="radio"/>	<input type="radio"/>	<input type="radio"/>	<input type="radio"/>
	Strongly disagree	Somewhat disagree	Undecided	Somewhat agree	Strongly agree

Survey *(continued)*

3) The following portions of *Church Safety Solutions* are useful for me and my church:

Safety Articles	<input type="radio"/>	<input type="radio"/>	<input type="radio"/>	<input type="radio"/>	<input type="radio"/>
	Strongly disagree	Somewhat disagree	Undecided	Somewhat agree	Strongly agree
Checklists	<input type="radio"/>	<input type="radio"/>	<input type="radio"/>	<input type="radio"/>	<input type="radio"/>
	Strongly disagree	Somewhat disagree	Undecided	Somewhat agree	Strongly agree
Lessons of Loss	<input type="radio"/>	<input type="radio"/>	<input type="radio"/>	<input type="radio"/>	<input type="radio"/>
	Strongly disagree	Somewhat disagree	Undecided	Somewhat agree	Strongly agree
References Cited	<input type="radio"/>	<input type="radio"/>	<input type="radio"/>	<input type="radio"/>	<input type="radio"/>
	Strongly disagree	Somewhat disagree	Undecided	Somewhat agree	Strongly agree

4) The following potential changes to Church Safety Solutions would be beneficial to me and my church:

Shorten the articles (cover material in less detail)	<input type="radio"/>	<input type="radio"/>	<input type="radio"/>	<input type="radio"/>	<input type="radio"/>
	Strongly disagree	Somewhat disagree	Undecided	Somewhat agree	Strongly agree
Lengthen the newsletter (to cover more than one topic/month)	<input type="radio"/>	<input type="radio"/>	<input type="radio"/>	<input type="radio"/>	<input type="radio"/>
	Strongly disagree	Somewhat disagree	Undecided	Somewhat agree	Strongly agree
Lengthen "Lessons of Loss" (to include more detailed examples)	<input type="radio"/>	<input type="radio"/>	<input type="radio"/>	<input type="radio"/>	<input type="radio"/>
	Strongly disagree	Somewhat disagree	Undecided	Somewhat agree	Strongly agree
Letters to the editor (add this to the publication)	<input type="radio"/>	<input type="radio"/>	<input type="radio"/>	<input type="radio"/>	<input type="radio"/>
	Strongly disagree	Somewhat disagree	Undecided	Somewhat agree	Strongly agree
Monthly survey (add this to the publication so I can compare my church and others)	<input type="radio"/>	<input type="radio"/>	<input type="radio"/>	<input type="radio"/>	<input type="radio"/>
	Strongly disagree	Somewhat disagree	Undecided	Somewhat agree	Strongly agree

Additional comments:

Below are the three ways you can return your survey to Zurich. If you include your contact information, a Zurich Risk Engineering Consultant may contact you to further discuss your thoughts. Thank you.

Mail: 1400 American Lane, Schaumburg, IL 60196, attention: Peter Kim
 Fax: 847-605-6403, attention: Peter Kim
 Email: churchsafety.solutions@zurichna.com

References

Church Safety Solutions January 2007 edition, Cold Weather Preparation

Church Safety Solutions March 2007 edition, Ladder Injuries Cost Churches \$1.4 million

Church Safety Solutions April 2007 edition, Peeling the Layers Off Roof Damage

National Fire Protection Association 909, Code for the Protection of Cultural Resource Properties – Museums, Libraries, and Places of Worship, 2005 Edition

Zurich Risk Topics:
1-2.013, January 2007, Tips for wintertime walking to avoid slips and falls

If you have any questions or if you would like to receive electronic copies of any of the referenced materials above, please write to us via email at: churchsafety.solutions@zurichna.com.

You may also contact us for assistance regarding any safety or risk control topic at:

Dusti Butler
Risk Engineering Service Coordinator for the UCCIB Program
Zurich Services Corporation
(773) 296-2481
dusti.butler@zurichna.com

Zurich Services Corporation

1400 American Lane, Schaumburg, Illinois 60196-1056
800 982 5964 www.zurichservices.com

Zurich Services Corporation
Risk Engineering



ISO 9001:2000

Quality-Assured Solutions Provider

The information in this publication was compiled by Zurich Services Corporation from sources believed to be reliable. We do not guarantee the accuracy of this information or any results and further assume no liability in connection with this publication, including any information, methods or safety suggestions contained herein. Moreover, Zurich Services Corporation reminds you that this publication cannot be assumed to contain every acceptable safety and compliance procedure or that additional procedures might not be appropriate under the circumstances. The subject matter of this publication is not tied to any specific insurance product nor will adopting these procedures insure coverage under any insurance policy.

©2007 Zurich Services Corporation

Because change happenzSM



ZURICH[®]